

Libero®

FREEZER HORIZONTAL
LFH-400B



Termostato exterior



Interior de acero prepintado



TRIPLE FUNCIÓN
REFRIGERADO • CONGELADO SUAVE • CONGELADO ULTRA



2 AÑOS DE GARANTÍA
Libero

Características

- Bajo consumo de energía. eficiencia energética A+
- Únicos con TRIPLE FUNCIÓN: refrigerado, congelado suave o congelado ultra
- Termostato exterior ajustable.
- Cerradura con llave.
- Incluye un canastillo.
- Temperatura de trabajo 8°C a -18°C.
- Color blanco.



CAPACIDAD NETA TOTAL (Lts)	400
CONSUMO ENERGÍA	24,27 Kwk/mes
TEMPERATURA MÍNIMA	220V / 50Hz
MEDIDAS PRODUCTO (cm)	-18°C
PESO BRUTO	83,5x136,5x73
EAN	58 Kg
	7804646980275

83,5 cm

73 cm

163,5 cm

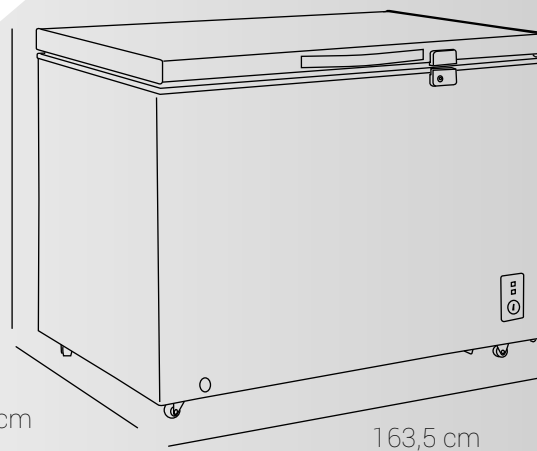

www.liberochile.cl